

A review on supercapacitor materials and developments

Mustafa Ergin Şahin^{1*}, Frede Blaabjerg², Ariya Sangwongwanich²

¹Department of Electrical and Electronics Engineering, Recep Tayyip Erdoğan University, 53100 Rize, Turkey

²Department of Energy Technology, Aalborg University, Pontoppidanstraede, 9220, Aalborg East, Denmark

Received: 24 November 2020; Accepted: 23 December 2020; Published: 30 December 2020

Turk. J. Mater. Vol: 5 No: 2 Page: 10-24 (2020) ISSN: 2636-8668

SLOI: <http://www.sloi.org/sloi-name-of-this-article>

*Correspondence E-mail: mustafaerginsahin@yahoo.com.tr

ABSTRACT Energy storage is a big problem today in the world for humanity depend on the challenges of conventional storage devices. So the researchers are studying to invent new energy storage devices and materials for many years. The supercapacitor (SC) is invented and presented as an alternating storage device recently. There were a lot of studies about SC in literature. These studies are focused on materials of SC components, modelling of SC, and applications of SC. In this paper, the working principle of SC, the advantages of SC, the classification of SC, and new developments of SC are investigated. Some material applications of SC are presented in this study also. The manufacturing developments are investigated for some SC materials and presented some novel applications also.

Keywords: Capacitor; Supercapacitor; Classification of Supercapacitor; Supercapacitor Materials; Material Applications of Supercapacitor

Cite this article: M.E. Şahin, F. Blaabjerg, A. Sangwongwanich. A review on supercapacitor materials and developments. Turk. J. Mater. 5(2) (2020) 10-24.

1. INTRODUCTION

The conventional storage devices' life is not so long and has some harmful contaminants for nature. Also, they have some technical drawbacks. So the scientists are researching for a big capacity and long life storage devices for many years. The SCs have proposed an alternating solution for alone and hybrid applications with the other storage devices as new technology. These devices have high power density, quick charge-discharge low input resistance, extended lifetime, and environmentally friendly [1]. To learn and analyse these components is required to search the evaluation, classification, working principles, and application of SC as a review.

The invention of SC is a very new technology and have a live history. Firstly, General Electric Company engineers began to design capacitors with porous carbon electrodes in the early 1950s, and in 1957 developed a low voltage electrolytic capacitor by Becker [2]. Standard Oil of Ohio (SOHIO) company developed another version of the SC in 1966 but did not commercialize their invention [3]. It is patented by Donald L. Boos that is called an electrolytic capacitor with activated carbon electrodes [4]. The first SC was developed in 1982 for military applications by the Pinnacle Research Institute (PRI), and it is called PRI ultracapacitor. In 1992, Maxwell Technologies took over this development for power applications and called them "Boost Caps" [5]. A high voltage tantalum electrolytic capacitor developed by Evans in 1994, and it is called Electrolytic-Hybrid Electrochemical Capacitor [5]. They combine electrolytic and electrochemical capacitor features, but their high costs limited them to specific military applications. Recent developed lithium-ion capacitors combine an electrostatic carbon electrode with an electrochemical electrode to increase the capacitance value [7]. Many companies and universities research departments are working to improve SC specific characteristics and to reduce production costs today [8].

SCs consists of two solid electrodes and a liquid electrolyte different from a ceramic or electrolytic capacitor. These electrodes are separated by a separator and polarized by an applied voltage. The ions in the electrolyte form electric double layers of opposite polarity to the electrode's that is called an electric double layer (EDL) [9]. To increase the capacitance of SCs uses two storage principles in the EDL electrodes [10]. Double-layer capacitance is one of them where electrostatic

storage is achieved by separation of charge in a Helmholtz double-layer [11]. Pseudo capacitance is the other where electrochemical storage is achieved by faradaic redox reactions [5].

The properties of SC originate from the mutual effect of their electrode and electrolyte materials that determines the functionality and characteristics of the capacitors. The usually used electrode material for EDL capacitors is carbon in different appearances such as activated carbon, carbon fiber cloth, carbon aerogel, graphite, graphene, and carbon nanotubes [11-13]. Typical electrode materials for pseudocapacitors are MnO_2 and RuO_2 . Every material cannot be used as an electrode for pseudocapacitors which exhibits faradaic behavior [14]. A pseudocapacitive material uses electron-conducting polymers that have low ESR and relatively high capacitance and cycles [15]. The hybrid SCs combines two electrodes with a high amount of pseudocapacitance and double-layer capacitance. Hybrid-type SCs composite electrodes are manufactured from carbon-based materials like metal oxides and conducting polymers [16]. Rechargeable battery electrodes influenced the development of hybrid-type supercapacitor electrodes as for lithium-ion capacitors [17]. Electrolytes consist of a solvent and dissolved chemicals. The more ions the electrolyte contains, the better its electrical conductivity. Aqueous, organic, and ionic electrolytes are also can be used [18]. Separators have to separate the two electrodes physically and can be very thin. Although inexpensive components are used generally, more complex designs use nonwoven porous polymeric films [19]. The electrodes connect to current collectors of the capacitor's terminals, and they must be able to spread high peak currents.

The SC has advantages in applications where high power density and a lot of charge/discharge cycles or a longer life is required. General applications from low power to high power for shorter periods. SCs do not support alternating current (AC) applications. Consumer electronics [20, 21], tools, power supply [22], voltage stabilization [23], microgrids [24], renewable energy storage [9], energy harvesting [25, 26], street lights [27], medical applications [28], military and automotive applications [29-31], energy recovery [32-35] are some applications of SC. Standardized test protocols are requiring for applications ranging from low to high peak currents [36]. Researches focus on improving specific energy, reducing internal resistance, increasing lifetimes, expanding temperature range, and reducing costs today [8].

Another topic related to the development of SC is the assembly and manufacturing of SCs. The three widespread SC designs used commercially are coin cells, cylindrical cells, and pouch cells. Although the fabrication techniques of commercial SCs are normally trade secrets, laboratory techniques for fabricating and made public [37-41]. Stacking of SCs and stack performance is another research topic. Simulation of SCs based on a simplified equivalent circuit model is made for SC stack performance investigation [37, 42]. This stack that is called a module is specifically engineered to provide solutions for UPS, telecommunications, and other industrial electronics applications [42, 43].

The developments and history of SC are given more detail in this review paper firstly. The working principles and classifications of SC are given secondly. The structure and materials of SCs are given and investigated for EDL and pseudocapacitors thirdly. Some material applications and products with specific production methods about SC are investigated in this paper lastly. A comprehensive literature review about SCs materials and developments is given in this paper.

2. WORKING PRINCIPLES AND SPECIFICATIONS OF SUPERCAPACITORS

The working principle of SC is based on electrostatic capacitors. The elementary equation for all capacitors is given as in Equation 1;

$$C = \frac{\epsilon_0 \times \epsilon_r \times A}{d} \quad (1)$$

In this equation the surface area of the electrode is A, the permittivity of free space is ϵ_0 , the relative permittivity of the dielectric material is ϵ_r , and the distance between two oppositely biased electrodes is d as shown in Figure 1(a). The capacitance value of a capacitor can be increased according to the relationship in Equation (1) by changing the dielectric constant of the material, surface area, and the interplanar thickness. Modifying the material system and design of the capacitor an increase can be achieved, and it will be investigated in the next sections [44]. The basic structure of an SC consists of aluminium current collectors and electrodes instead of dielectric materials. Generally, out of activated carbon saturated in an organic or aqueous electrolyte, and a separator is inserted between the two electrodes to insulate them is shown in Figure 1 (b). The mounting of the SC is performed as for the other capacitors [45]. The operation principle of the SC is based on the storage of the energy by the distribution of the ions coming from the electrolyte in the vicinity of the surface of the two electrodes. The two interfaces created a zone of space charge that is called the electrical double layer (EDL). Therefore, SC is electrostatic, and there is no electrochemical reaction [43, 45].

The Helmholtz theory explains physical phenomena that occur between ionic and an electronic electrode interface that is modelled by two superficial distributions of charges. Helmholtz capacitance is composed of a thin layer at the electrode/electrolyte interface. The combination of both principles affects the distribution of charge in time during the charging process that is presented in Figure 1 (c). The capacitance of SC is driven by the Helmholtz layer which consists of the charge stored at the electrode/electrolyte interface, and the charges in the electrolyte are assumed to be drifted by an electric field closer to this interface. This drift produces a depletion region, into which the charge from bulk electrolyte diffuse [46].

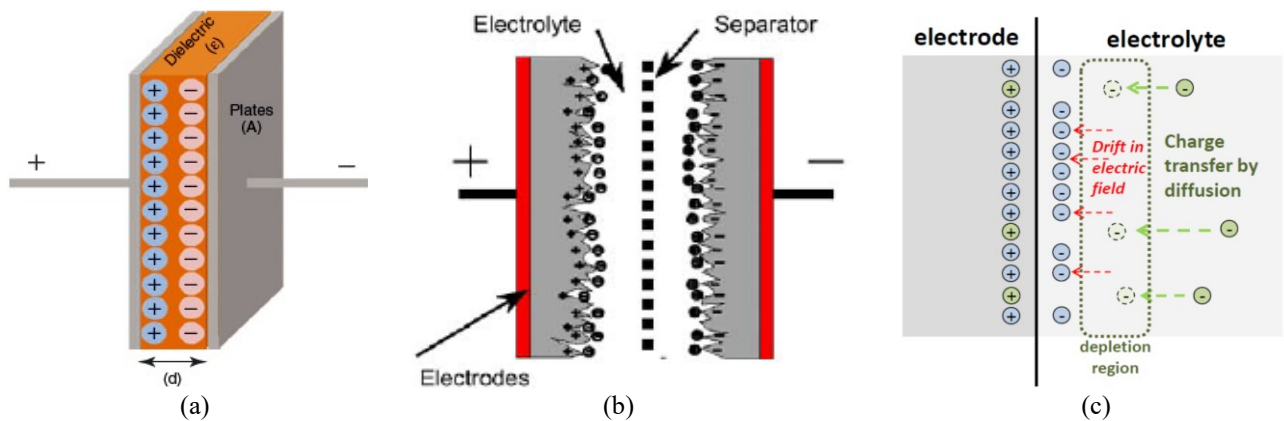

Fig. 1. (a) Structure of electrostatic capacitor, (b) structure of supercapacitor, (c) charge transfer of SC between Helmholtz and diffusion layers [43-46].

SC does not consist of a dielectric material like ceramic or electrolyte capacitors. SCs consist of two porous electrodes, an electrolyte, a separator, and current collectors as seen in Figure 1. SCs use the EDL that is formed at each interface of the solid electrode and liquid electrolyte where the active carbon powder contacts. An SC interface including salt electrolyte, and a separator to prevent contact between the electrodes. The electrodes are located on the collectors and coated with activated carbon powder. When the SC charged, the negative ions and vacancies on the positive electrode side and the positive ions and the electrons on the negative electrode side are aligned across the interface. This state of alignment of ions and electrons is called an electrical double-layer capacitor (EDLC), and this charge structure is shown in Figure 2(a). The process of discharge is shown in Figure 2 (b). The ions are no strongly attracted to current collectors and get distributed through the electrolyte. As a result, the charge state on both current collector decreases [47, 48].

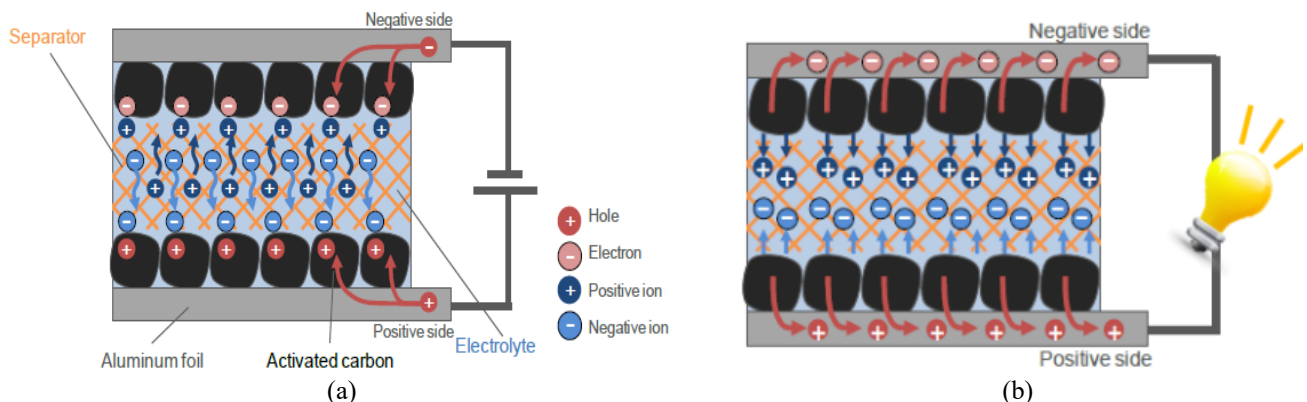

Fig. 2. Two states of SC; (a) Charge state of SC, (b) discharge state of SC [47, 48].

The specifications of the SCs are summarized in Table 1. The advantages of SCs give superiorities from the other conventional storage devices in many ways. When compared to the superiorities and drawbacks, it looks to use them together with the other storage devices [1]. SCs are low voltage components and require safety operation for the voltage remains within specified limits. Standard SCs with aqueous electrolytes are specified with a rated voltage of 2.1 to 2.3 V, and capacitors with organic solvents are rated 2.5 to 2.7 V [18]. For higher application voltage it is required to connect cells in series. The rated capacitance value is 1 F to 1000 F, and higher application capacitances require connecting cells in parallel [9].

Table 1. The main specifications of SC.

1	High power density and low energy density
2	Quick charging and discharge does not blow-up
3	In case of accidental short connection
4	When it becomes fully charged stops accepting energy
5	Extremely small internal resistance ESR ($\approx 0.01 \Omega$)
6	Long shelf life and extended lifetime
7	No gas emissions and environmentally safe

It can be seen from the plot in Figure 3 that the SC can a bridge between batteries and capacitors [37]. Although the SC energy density is better than the conventional capacitors, the power density of capacitors is better than the SC. However,

the batteries' energy density is better than the SC, but the SCs' power density is better than the SCs. Cyclic Voltammetry (CV) and Galvanostatic Charge-discharge (GCD) electrochemical techniques are two known methods used to evaluate the capacitance of materials [37]. Specific energy density is expressed in Equation 2.

$$ED = \frac{1}{2} C_s (\Delta V)^2 = \frac{1}{2} \frac{C}{m} (\Delta V)^2 \quad (2)$$

The specific capacitance from CV or GCD techniques is C_s , and the operating potential range is ΔV . How quickly a device can deliver energy under a constant current density to external loads is defined as a specific power density. The maximum specific power density is calculated in Equation 3.

$$PD_{max} = \frac{(\Delta V)^2}{4mR_{ESR}} \quad (3)$$

The potential range is ΔV , the mass of the active materials is m , and the equivalent series resistance (ESR) within the cell is RESR.

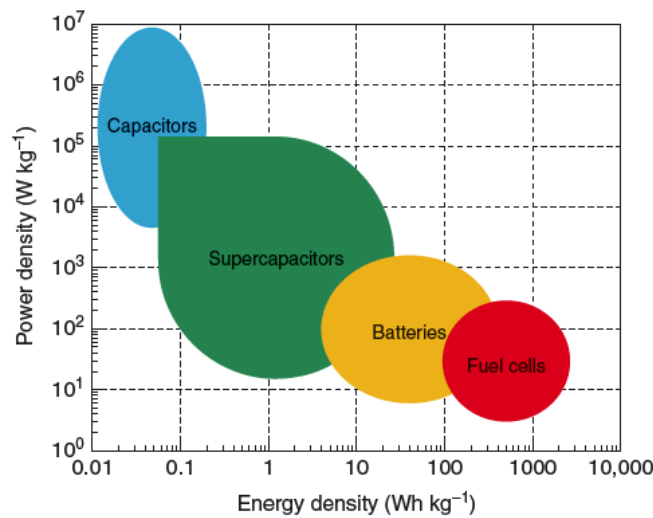

Fig. 3. Comparison of storage devices in energy and power density [37].

3. CLASSIFICATION OF SUPERCAPACITORS

SC basically can be classified depending on manufacturing and construction details. SC can be made flat with a pair of electrodes, wound in a cylindrical case, or stacked in a rectangular case style. SCs are made of two metal current collectors, each coated with an electrode material. The large electrode material area is about 100,000 times greater than the smooth surface. The electrodes are separated by an insulator separator to prevent short circuits. Then it is rolled or folded into a cylindrical or rectangular shape and can be stacked in an aluminium can be seen in Figure 4 (a) and (b). The cell is saturated with an organic or aqueous type liquid or viscous electrolyte then. The electrolyte enters the pores of the electrodes and serves the conductive connection between the electrodes across the separator [49, 50]. The wound SC consists of terminals (1), safety vent (2), sealing disc (3), aluminium can (4), positive pole (5), separator (6), carbon electrode (7), collector (8), carbon electrode (9), negative pole (10) parts as seen in Figure 4 (a). The stacked electrode consists of a positive electrode (1), a negative electrode (2), and a separator (3) as seen in Figure 4 (b).

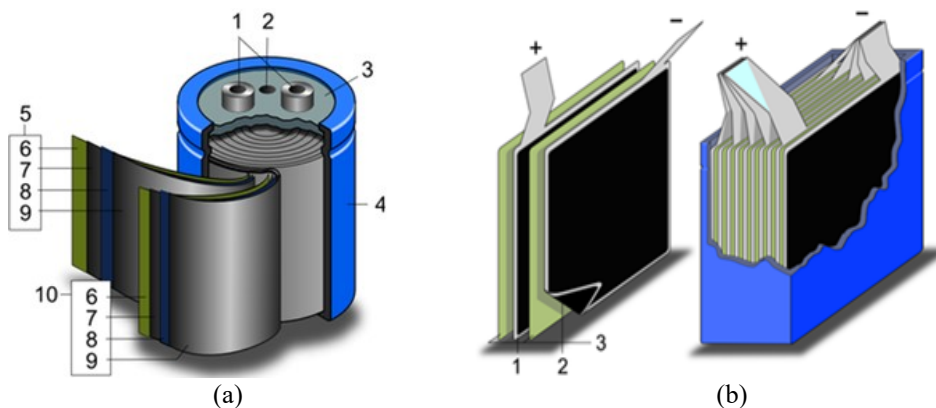

Fig. 4. Schematic constructions of an (a) wound supercapacitor, (b) with stacked electrodes [49, 50].

The operation principle of SC is based on energy storage and distribution of the ions coming from the electrolyte to the surface area of the electrodes. Depending on how energy is stored, SCs can be divided into EDLCs and pseudocapacitors (PCs). In EDLC charge storage occurs at the interfaces between the electrolyte and electrodes is shown in Figure 5(a). Pseudocapacitors (PCs) involve reversible and fast Faradaic redox reactions for charge storage and order to increase the capacitance of an SC as shown in Figure 5(b). A hybrid supercapacitor (HSC) stores charges by matching the capacitive carbon electrode with a pseudocapacitive or lithium-insertion electrode as shown in Figure 5(c). Therefore, depending on the energy storage method SCs are classified into three main classes EDLCs, PCs, and HSCs are shown in Figure 5 [37, 51, 52].

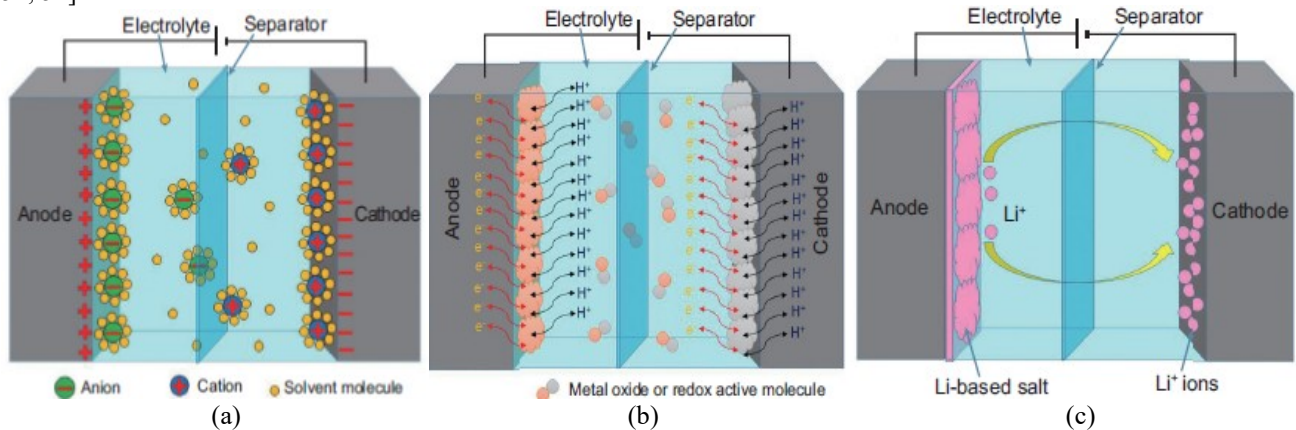

Fig. 5. Classification of (a) electrical double-layer capacitor (EDLC), (b) pseudo capacitor (PC) and (c) hybrid supercapacitor (HSC) types [51].

These SC types are classified in more detail as is shown in Figure 6. EDLCs are made using two carbon-based materials for electrodes, an electrolyte, and a separator. EDLCs can be either store charge electrostatically or via a non-faradic way without transfer of charge loads. So the energy storage principle of EDLCs is the electrochemical double-layer [52-54]. Three main types of EDLCs have for SC in terms of the carbon content. Activated carbon, carbon nanotubes (CNTs) and graphene, carbon aerogels (nanopores), carbon foams (micropores), and carbide-derived carbon (CDC) (controllable pore size) are the main types of EDLC which are shown in Figure 6 [44]. The details of these types are given in the next section as an electrode material.

Compared to EDLCs, the pseudocapacitors store charges via a faradic process that involves the transfer of charge loads electro-statically between electrode and electrolyte [55]. When a potential is applied to a pseudocapacitor reduction, oxidation takes place on the electrode material. This process involves the passage of charge across the double layer, resulting in faradaic current passing through the supercapacitor cell. This faradaic process leads to pseudocapacitors having higher energy densities than EDLCs. This type of capacitor includes metal oxides, metal-doped carbon, and conductive polymers electrode materials that are shown in Figure 6 [56]. Conductive polymer types of SCs have high capacitance and conductivity, low ESR, and low cost compared to carbon-based EDLCs. The metal oxide materials provide very high conductivity. One of the most researched metal oxides is RuO₂ and has low ESR and very high specific capacitance. However, pseudocapacitors also have a shorter life cycle, and power density depends on the redox reactions in the SC [44, 52].

A hybrid SC system offers a union of the energy source of a battery-like electrode with a power source of a capacitor-like electrode in the same cell. It is possible to increase the cell voltage with a correct electrode combination that leads to an improvement in energy and power densities [52, 57]. This type of SC consists of polarizable electrodes such as carbon and non-polarizable electrodes such as metal or conducting polymer. Faradaic and non-faradaic processes are used to obtain high energy storage through both the battery type and the capacitor type electrode. These have resulted in better cycling stability and lower costs than EDLCs [44, 58, 59]. The faradaic electrode results in an increase in energy density at the price of cyclic stability, which is the main drawback of hybrid devices compared to EDLCs. The SC researchers have focused on the three different types of hybrid SCs currently, which can be distinguished by their electrode configurations asymmetric, composite, and battery-type that is illustrated in Figure 6 [52, 60]. Hybrid SC is one of which exhibits mostly electrostatic and the other electrochemical capacitance that is called superbattery. The superbattery has been proposed to represent those hybrid devices behaves like the SC and the rechargeable battery recently [50, 61].

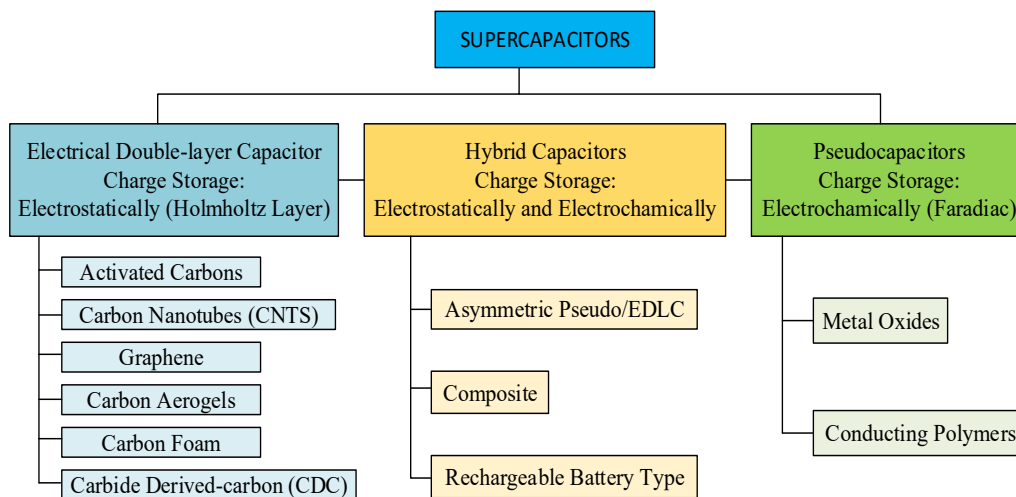

Fig. 6. Classification flowchart of SC [44, 50, 52].

4. MATERIALS OF SUPERCAPACITORS

The SCs' properties are related to the interaction of their internal materials. The functionality and thermal and electrical characteristics of the capacitors are determined by the electrode material combination and electrolyte type [50]. In recent years there were some comprehensive studies in this area. The comprehensive IDTechEx report, "Supercapacitor Materials and Technology Roadmap between 2019 to 2039." includes over 60 organizations [62]. The new IDTechEx report, "Supercapacitor Materials and Formats between 2020 to 2040." displays why Toyota, Volkswagen, the \$100bn CRRC in China, and other giants now see SCs as a potentially large market [63]. According to these reports materials will control SC performance and cost in the future. The percentage of new research is included in these reports on hierarchical and exohedral electrodes such as graphene, CNT, metal-oxide, and Metal-organic framework (MOF). Also, the challenges and opportunities of hybrid (BSH) pseudocapacitors, the necessity of increasing energy density, trade-offs of other parameters, with an appraisal from experts deeply involved in these reports are seen [62, 63]. The SC materials are investigated as electrode materials, electrolyte materials, separators, and collectors mainly.

4.1. Electrode Materials

SC electrodes are generally thin coatings and electrically connected to a conductive, metallic current collector. The electrodes must have good conductivity, high-temperature stability, long-term chemical stability, high corrosion resistance, and high surface areas per unit volume and mass, also they are environmentally friendly, and have low cost [50]. The most commonly used electrode material for SCs is different types of carbon such as activated carbon (AC), carbon fiber-cloth (AFC), carbide-derived carbon (CDC), carbon aerogel, graphite, graphene, and carbon nanotubes (CNTs) [10-13]. CNTs are designed carbon with superior properties compared to AC. The long 1-D structure of CNTs offers excellent mechanical properties and prevents the scattering of electrons, exceeding the electrical conductivity of AC. Graphene is a flat 2-D monolayer sheet of carbon atoms as the building blocks is illustrated in Figure 7 [37].

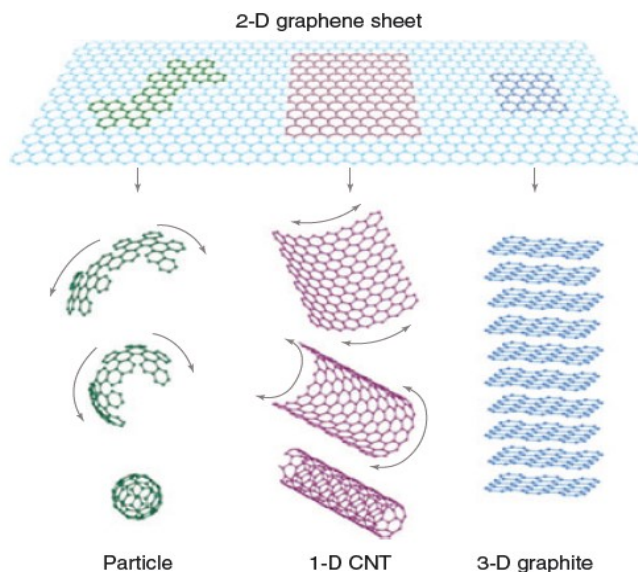

Fig. 7. The 2-D graphene sheet, 1-D carbon nanotubes, and 3-D graphite picture [37].

The first material chosen for EDLC electrodes is activated carbon even though its electrical conductivity is very low than metals it is enough for SCs. The solid form activated carbon called consolidated amorphous carbon (CAC) also is cheaper than other carbon derivatives, and one of the most used electrode material for SCs [5, 11]. Another activated carbon derivative is activated carbon fibers (ACF) that have about 10 μm diameter. They have micropores that can be controlled readily and a very narrow pore-size [12]. The carbon aerogel is a highly porous ultralight synthetic material, derived from an organic gas gel. Aerogel electrodes are more conductive than most activated carbons [64]. The carbide-derived carbon (CDC) is a family of carbon materials known as tunable Nanoporous carbon derived from carbide precursors that are transformed into pure carbon via decomposition processes [65-66]. The other most widely used electrode materials are random porous carbons due to their surface area, good electrical properties, and acceptable cost. The majority of random porous carbons are produced from carbon-rich organic precursors by physical or chemical activation [67].

Graphene is also called a nanocomposite paper in which atoms are arranged in a regular hexagonal pattern, and it is a one-atom-thick sheet of graphite that is seen in Figure 8 (a) [68, 69]. Graphene has a 2630 m^2/g specific surface area and 550 F/g capacitance theoretically [70]. CNTs are carbon molecules with a cylindrical nanostructure also called Bucky tubes. They have a hollow structure with walls formed by graphite as seen in Figure 8 (b) [50]. Due to the high power density surface area and high conductivity, carbon nanotubes can increase the SC efficiency [71].

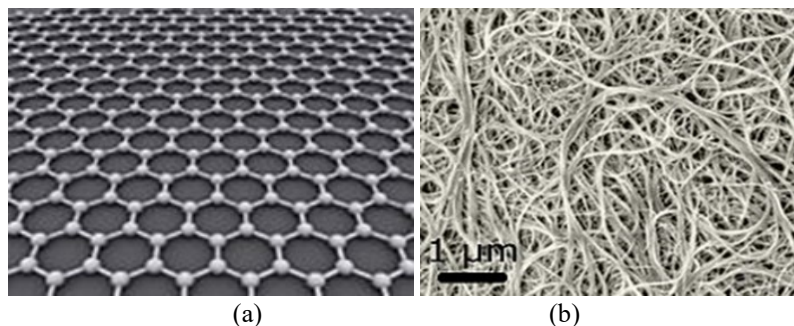

Fig. 8. (a) Graphene made of carbon atoms in atomic-scale, (b) SEM image of carbon nanotube [50].

MnO_2 and RuO_2 materials are used as electrodes for pseudocapacitors since they act as a capacitive electrode and exhibiting faradaic behavior. Pseudocapacitors occur within the active electrode materials created through faradaic redox reactions. Every material exhibit faradaic behavior cannot be used as an electrode for pseudocapacitors such as $\text{Ni}(\text{OH})_2$ as a battery type electrode [14]. Electrodes of transition metal oxides are described in research [72] that exhibited high amounts of pseudocapacitance. Oxides of transition metals include such as ruthenium (RuO), iridium (IrO), iron alone, or in combinations generate strong faradaic electron–transferring reactions [54]. Charge/discharge voltage occurred about 1.2 V per electrode for this pseudocapacitance what is about 720 F/g and nearly 100 times higher than for EDLC using activated carbon electrodes for several hundred-thousand cycles [73]. Electron conducting polymers used as a pseudocapacitive material. They have high conductivity that is resulted in low ESR and high capacitance. This conducting polymers have different types, and for example, polyacene electrodes provide up to 10.000 cycles [15, 74].

All commercial hybrid SCs are asymmetric, and they combine an electrode with a high amount of pseudocapacitance or a high amount of DLC. The faradaic pseudocapacitance electrode with their higher capacitance provides high specific energy, while the non-faradaic EDLC electrode enables high specific power [50]. Composite electrodes for hybrid-type SCs are constructed from carbon-based material like metal oxides and conducting polymers. Producing good pseudocapacitance and well double-layer capacitance, CNTs give a backbone for a homogeneous distribution of metal oxide or electrically conducting polymers (ECPs) [75, 76]. The development of electrodes for new hybrid-type supercapacitor electrodes influenced the rechargeable battery electrodes [71]. However, they have not offered commercially, some asymmetric hybrid SCs were developed by scientists. The positive electrode of these hybrid SCs is based on a real pseudocapacitive metal oxide electrode, and the negative electrode on an EDLC is an activated carbon electrode. Their higher voltage and higher specific energy are an advantage of these SCs [50].

4. 2. Electrolytes Materials

Although most of the studies are focus on electrode materials of electrolytes also are significant in SC performance. A solvent and dissolved chemicals consist of an electrolyte that makes it electrically conductive and increases with ions quantity in the electrolyte [50]. Electrolytes influence the operational voltage window of cells and their resistance. Energy density is proportional to the square of the voltage window, and the ionic resistivity is inversely proportional to the cell's power capability [57]. Aqueous, organic, and ionic liquid electrolytes are currently available for SCs [37]. The electrolyte determines the operating voltage, temperature range, ESR, and capacitance characteristics of SC. For example, an aqueous electrolyte achieves capacitance values of 160 F/g , while an organic electrolyte achieves only 100 F/g with the same activated carbon electrode [77].

On the other side, water is a perfect solvent for inorganic chemicals and aqueous electrolytes relatively. Water offers high conductivity values of about 100 to 1000 mS/cm when used with acids such as sulphuric acid (H_2SO_4), alkalis such as potassium hydroxide (KOH), or salts such as quaternary phosphonium salts. Aqueous electrolytes are used in SCs with low specific energy and high specific power, which have a 1.15 V dissociation voltage per electrode and a relatively low

operating temperature range [48, 50]. Electrolytes with organic solvents such as acetonitrile, propylene carbonate, tetrahydrofuran, and solutions such as tetraethylammonium tetrafluoroborate (N(Et)₄BF₄) or triethyl (metyl) tetrafluoroborate (NMe(Et)₃BF₄) are more expensive than aqueous electrolytes, but they have a higher separation voltage and a temperature range [48, 50, 78]. Ionic electrolytes consist of liquid salts that can be stable in a wider electrochemical window, and they enable capacitor voltages above 3.5 V, besides they have an ionic conductivity lower than aqueous or organic electrolytes [18]. A comparison of various materials for different electrolyte materials used in electrochemical capacitor electrode materials is given in Table 2, where F/g and F/cm³ are the electrode material-specific capacitance [77].

Table 2. Various materials properties in SC electrode and electrolyte material [77].

Material	Density (g/cm ³)	Electrolyte	F/g	F/cm ³
Carbon cloth	0.35	KOH	200	70
		Organic	100	35
Activated carbon	0.7	KOH	160	112
		Organic	100	70
Aerogel carbon	0.6	KOH	50-75	
		Organic	100-125	84
Particulate carbon from SiC	0.7	KOH	175	122
		Organic	100	70
Particulate carbon from TiC	0.5	KOH	220	110
		Organic	120	60
Anhydrous RuO ₂	2.7	Sulphuric acid	150	405
Hydrous RuO ₂	2.0	Sulphuric acid	650	1300
Doped conducting polymer	0.7	Organic	450	315

4. 3. Separators and the Other Materials

Although much progress has been set in improving the performance of SC electrodes, little research has been initiated in developing separators. Badly designed separators can cause additional resistances in the cell and separators can negatively influence the performance of SCs. Separators have to physically separate the two electrodes to prevent a short circuit by direct contact. This separator can be very thin and must be very porous to minimize ESR. Natural materials such as glass are used as separators in the first stages of SC development. Developed polymer-based separators which have low cost, high flexibility, and porosity lead the separator markets [37, 50, 79, 80].

The majority of energy storage devices require current collectors which connect the electrodes to the capacitor's and supplement the performance of SC because of the active materials' insufficient conductivity. A current collector found within the cell is to transport current from electrodes to external loads. Current collectors must be electrically conductive and resilient in the cell environment, and aluminium, steel, and iron are popular current collectors. The current collector is either a metal foil or sprayed onto the electrode. They must be able to carry the high charge and discharge currents [37, 50, 81].

Sealing in cell mounting is very important to prevent the performance loss of SC. To avoid forming a corrosive galvanic cell housing, and collectors should be made from the same aluminium metal [50]. A sealant material duty is to prevent foreign contaminants from entering the cell that can cause electrolyte disruption and surface oxidation on electrodes and loss of life cycles [37]. Multiple SC is connected in series to supply a high voltage in commercial applications, but this connection requires a complicated sealing. Shunt resistances occur between neighboring cells as a result of improper sealing of cells in series, and it can reduce the overall efficiency of the device [82]. Polymer materials are selected as sealants for their flexibility, stability, resistance, and electrical insulation generally. [37]. Dry up failure is an open-circuit failure that is caused by evaporation of inner electrolytic solution to outside and occurs little by little for a long time. Then supercapacitors cannot work in the end. Some SCs package is designed to have good sealing to prevent dry up is seen in Figure 9 [46].

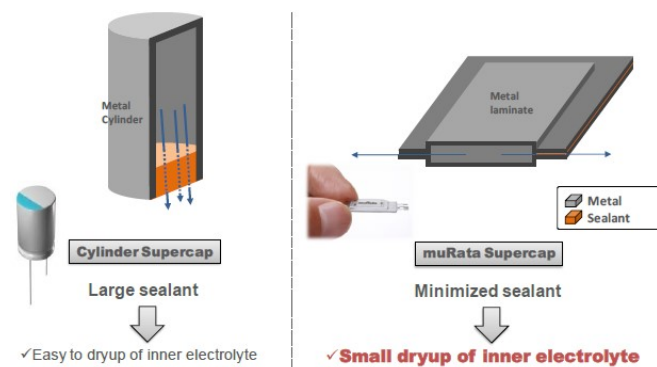

Fig. 9. Representation of a package design for reducing dry up [46].

5. SOME MATERIAL APPLICATIONS OF SUPERCAPACITORS

Flexible energy storage devices are rapidly growing for their potential applications in various portable electronic devices. The flexible solid-state SCs hold great expectations as favourite energy storage devices, which have advantages such as high flexibility, lightweight, and reduced interfacial resistance compared to the conventional SCs. The flexible solid-state SC devices include flexible electrodes, solid-state electrolyte, separator, and packaging material typically [67]. A low processing cost for flexible electrode manufacturing is developed through a vacuum-filtering method for high-performance hybrid electrode based on a MnO₂ nanotube (NT), and CNT composite films are shown in Figure 10 [83]. In this context, flexible and transparent SCs produced based on In₂O₃ nanowire/CNT heterogeneous films and observed an increase in specific capacitance with increasing numbers of In₂O₃ nanowires dispersed on the CNT films [84]. These flexible SCs can be integrated into wearable electronic devices that energies LEDs and electronic watches [51].

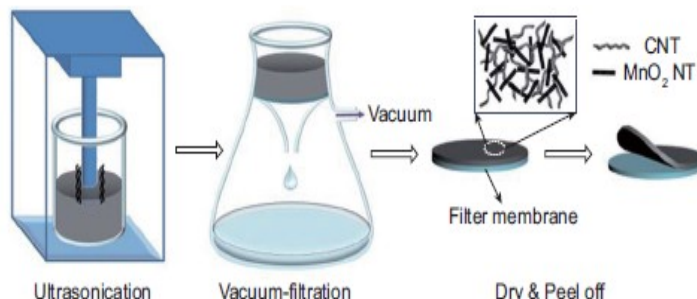

Fig. 10. The manufacturing process of flexible CNT/MnO₂ NT hybrid film [83].

Another flexible SC as a type of cable is produced on stainless steel (SS) wire using hydrothermal rGO nanosheets is presented in Figure 11 [85]. This flexible SC in redox additive electrolyte shows a maximum length capacitance of 18.75 mF/cm and a maximum energy density of 2.6 mWh/cm [51].

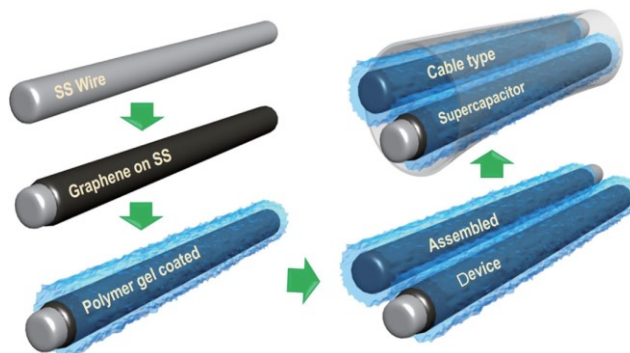

Fig. 11. Fabrication schematic of rGO based cable SC using different electrolytes [85].

The carbon-based CNT fibers have been manufactured by dry and wet-spinning methods that have attracted in the field of energy storage as a result of their excellent electrical conductivity, mechanical properties, and flexibility. Two twisted CNT fibers are used to fabricate a wire-shaped SC in a study and reported that it can be used in textiles [86]. However, the woven is a big challenge for the wire and fiber-shaped SCs with high electrochemical performance and with remarkable stretchability. The springlike fiber electrodes are presented as a breakthrough by a research group contain twisted CNTs that are provided the electrode with a high stretchability and elongation of over 300% as shown in Figure 12 [87, 88]. A fiber-shaped elastic SC is produced by placing two springlike fibers in parallel, and the specific capacitances obtained 18.12 F cm⁻³. As a result, this SC exhibited high stretchability and stability [67].

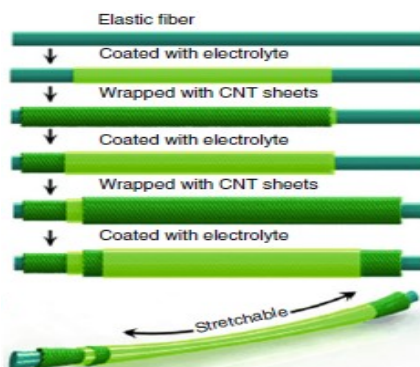

Fig. 12. The manufacturing process of highly stretchable coaxial structure, fiber-shaped SC [88].

In another study, polypyrrole (PPy) coated MnO₂ nanoparticles are deposited onto CNT based textile SC electrodes, which rises by 38% the electrochemical energy storage of MnO₂/CNT based flexible and stretchable SC as seen in Figure 13 [89]. The PPO based electrolyte included textile-based SCs mechanical bending, and tensile stress are illustrated in the figure also. A specific capacitance of 461 F/g in H₃PO₄-PVA electrolyte at 0.2-A/g current density and the capacitance holding was 96.2% even after 750 000 cycles are presented [51, 89].

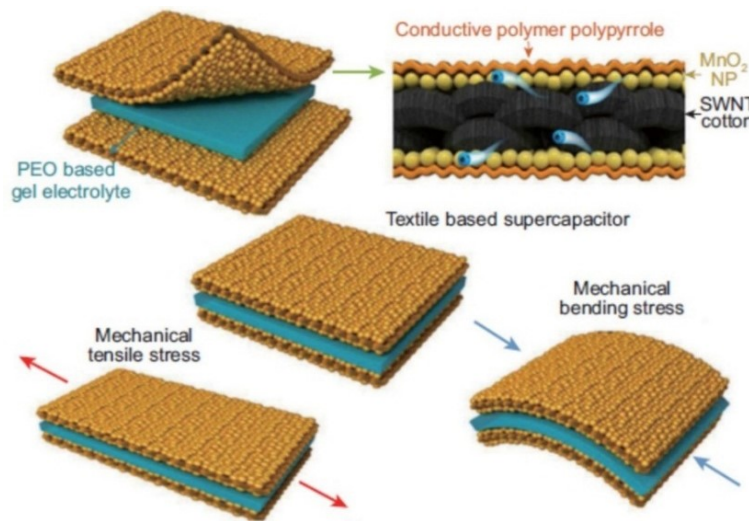

Fig. 13. The fabrication process of polypyrrole–MnO₂- coated textile SC [89].

In another study describes a design and manufacturing process for electrochemical SC with a 3D printing technique as shown in Figure 14. The Fused Deposition Modelling (FDM) technology was used to print the frame for the SCs, and the paste extruder system was used to print current collector layers, electrodes, and separator layers with electrolytes for this combination SC manufacturing system. The polylactic acid (PLA) filament material with a diameter of 2.89 mm is used to build the SC frame, and silver conductive paint material is used as the current collector in this experiment. To prepare the electrode slurry material is mixed an activated carbon (AC) with a CMC solution [90]. Electrodeposition of zinc and reduced graphene oxide on porous nickel electrodes for high performance SCs are researched in a study. Cyclic voltammetry (CV) and galvanostatic charge–discharge cycling (GCD) techniques were used to carry out the redox interactions, and cycling capacitive properties of the electrodes in KOH solution. Platinum (Pt) and gold (Au) foil were used as a counter electrode and the current collector in the electrochemical measurements, respectively [91].

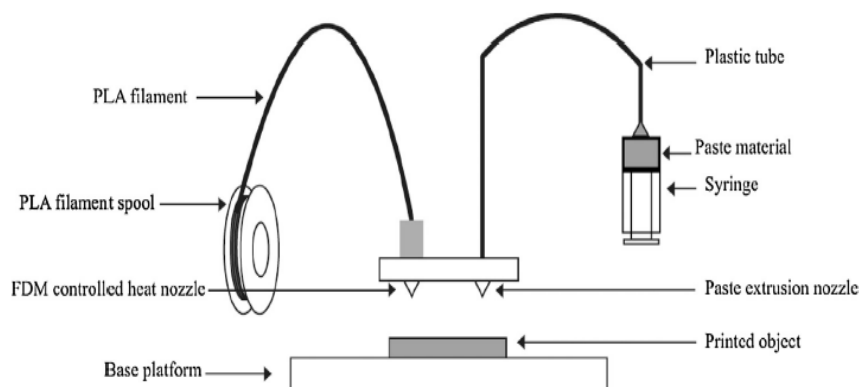

Fig. 14. SC manufacturing system of two 3D printing techniques combination [90].

On the other hand, laser reduction of graphene oxide (GO) is also getting significant interest and developed a laser writing technique in a stud to directly convert GO to rGO [92]. The structure of the laser-induced rGO was found to be porous. The capacitance is found to be highly dependent on the geometry of the patterned structure, and the highest area capacitance of 0.51 mF cm² is obtained. The laser-treated GO can supply an impressive conductivity, well-aligned, and with outstanding mechanical properties as shown in Figure 15 [38, 67, 93]. A GO film is supported on a flexible substrate, and a computer image is then laser irradiated on the GO film in a computerized LightScribe DVD drive. The GO film changes from golden brown color to black as it reduced to laser-scribed graphene as shown in Figure 15. The low-power infrared laser changes the stacked GO sheets into well-exfoliated few-layered LSG film, as shown in the cross-sectional SEM images in Figure 15. A symmetric EC is constructed from two identical LSG electrodes, ion-porous separator & electrolyte, and substrate as shown at the end of the process in Figure 15 [67, 93].

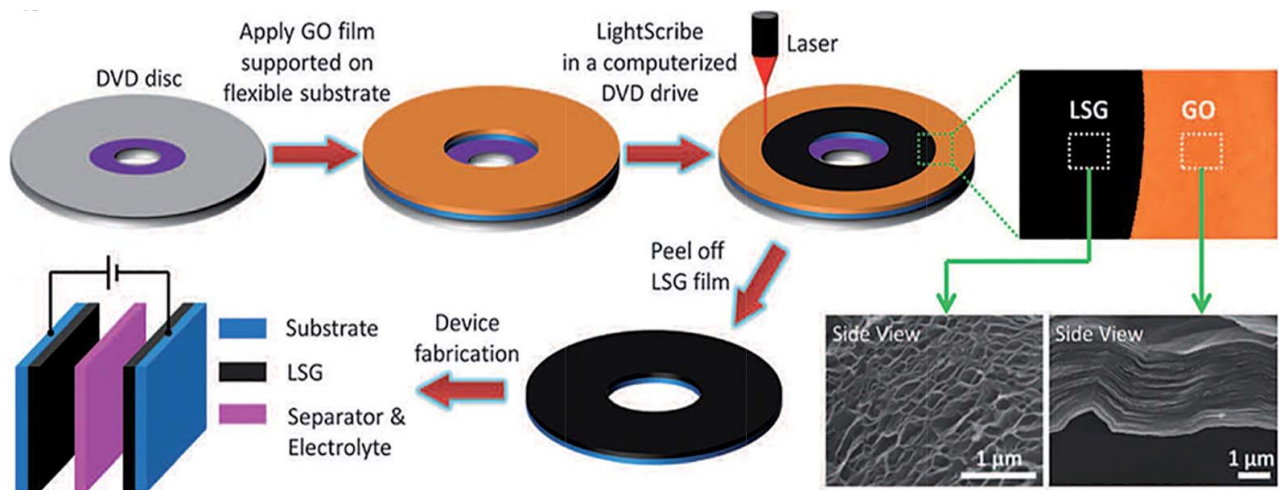

Fig. 15. The manufacturing process of laser-scribed graphene-based SC [93].

After processed by loading conductive carbon, cotton textiles with high porosity, large surface area, and hydrophilic functional groups on the surface, are an ideal electrode material for flexible SCs. A carbon-coated flexible fabric SCs by uniformly screen printing porous carbon into woven cotton is reported in a paper that is shown in Figure 16(a) [94]. The ion diffusion between electrodes and ions could improve by the porous structure of the cotton. The electrodes of this flexible SC achieved specific capacitances as high as 85 F g^{-1} at 0.25 A g^{-1} and good cyclic stability over 10,000 cycles [67]. Also, the idea of wearable electronics is becoming more realistic as scientists are integrating SC technology into clothing that is shown in Figure 16 (b). A research group manufactured a T-shirt that functioned like an SC at the University of South Carolina. It is purchased from a local store, soaked it in fluoride solution, and prepared for use. The clothing fibers surface area transformed into AC, displaying super capacitive action. Manganese dioxide is deposited on the activated-carbon T-shirt to further increased its energy performance additionally [37, 95].

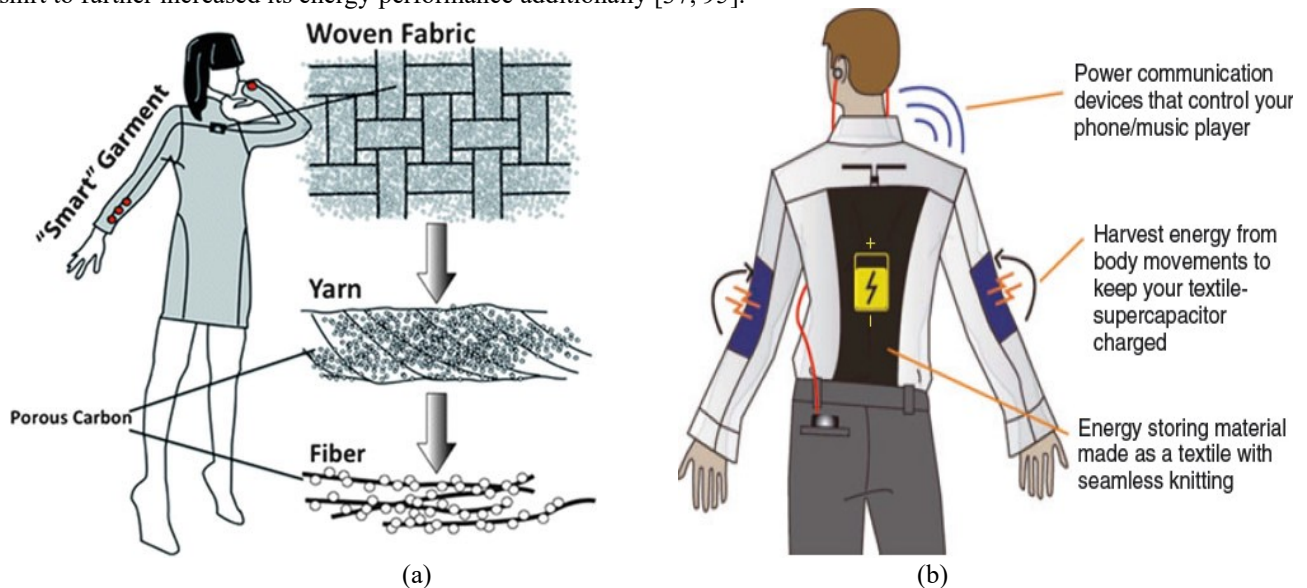

Fig. 16. (a) Idea of a porous textile SC integrated into a smart cloth [93], idea of integrated SC energy storage in wearable electronics [95].

4. CONCLUSIONS

The developments and history of SC were given in detail in this review paper firstly. The working principles and specifications of SC were given in this paper secondly. The classification of SC is made depending on the charge storage principle thirdly. The structure and materials of SCs were given and investigated for EDL and pseudo and hybrid capacitors. The electrode, electrolyte, separator, and other materials of SC were investigated also. Some material applications and products with specific production methods about SC were investigated in this paper lastly. A comprehensive literature review about SCs materials and developments were given in this paper. This review paper comes together with all the studies in this area in a comparable form for different specifications. So it will be informed and inspired by the researchers who will be aiming to study in this area. The economic analyses, developments in SC marked, and applications of SC are required to investigate, and it is aimed at a future study.

References

- [1] M. E. Glavin, W. G. Hurley. Optimizations of a photovoltaic battery ultracapacitor hybrid energy storage system. *Solar Energy* 86(10) (2012) 3009-3020.
- [2] J. Ho, R. Jow, S. Boggs. Historical Introduction to Capacitor Technology. *IEEE Electrical Insulation Magazine* 26(1) (2010) 20–25.
- [3] J. G. Schindall, The Change of the Ultra-Capacitors, *IEEE Spectrum* November 2007.
- [4] D. L. Boos. US 3536963 patent, Electrolytic capacitor having carbon paste electrodes. issued 1970-10-27.
- [5] A. M. Namisnyk. A survey of electrochemical supercapacitor technology. Technical report. Archived from the original on 2014-12-22. Retrieved 2015-02-21.
- [6] D. A. Evans, US 5369547 patent, Containers with anodes and cathodes with electrolytes. issued 1994-11-29.
- [7] Anonym, FDK, Corporate Information, FDK History 2000s. FDK. Retrieved 2015-02-21. Internet: https://www.fdk.com/company_e/ayumi2000-e.html
- [8] K. Naoi, P. Simon. New Materials and New Configurations for Advanced Electrochemical Capacitors. *Interface* 17(1) (2008) 34–37.
- [9] M. E. Sahin, F. Blaabjerg. A Hybrid PV-Battery/Supercapacitor System and a Basic Active Power Control Proposal in MATLAB/Simulink. *Electronics* 9(129) (2020) 1-17.
- [10] E. Frackowiak, F. Béguin. (May 2001). Carbon materials for the electrochemical storage of energy in capacitors. *Carbon* 39(6) (2001) 937–950.
- [11] M. S. Halper, J. C. Ellenbogen. Supercapacitors: A Brief Overview. MITRE Nanosystems Group, (March 2006) Retrieved 2015-02-16.
- [12] A. G. Pandolfo, A. F. Hollenkamp. Carbon properties and their role in supercapacitors. *J. Power Sources* 157 (1) (2006) 11–27.
- [13] K. Kinoshita. *Electrochemical Oxygen Technology*, Wiley (June 1992) ISBN 978-0-471-57043-1.
- [14] T. Brousse, D. Bélanger, J. W. Long. To Be or Not to Be Pseudocapacitive?. *Journal of the Electrochemical Society* 162(5) (2015) A5185–5189.
- [15] T. Yuden. Coin type PAS capacitor. Shoe Electronics Ltd. Notice for products (2020).

- [16] X. Li, B. Wei. (2012), "Facile synthesis and super capacitive behaviour of SWNT/MnO₂ hybrid films. *Nano Energy* 1(3) (2012) 479–487.
- [17] K. Naoi, W. Naoi, S. Aoyagi, J-I. Miyamoto, T. Kamino. New Generation Nanohybrid Supercapacitor. *Accounts of Chemical Research*. 46 (5) (2013) 1075–1083.
- [18] M. Salanne. Ionic Liquids for Supercapacitor Applications. *Topics in Current Chemistry* 375(3) (2017) 63.
- [19] A. Schneuwly, R. Gallay. Properties, and applications of supercapacitors, From the state-of-the-art to future trends, PCIM Conference (2000).
- [20] I. Genuth. Ultracapacitor LED Flashlight Charges In 90 Seconds – Slashdot. Internet:Tech.slashdot.org, 2008-12-10, Retrieved 2013-05-29.
- [21] M. Farhadi, O. Mohammed. Real-time operation and harmonic analysis of isolated and non-isolated hybrid DC microgrid. *IEEE Trans. Ind. Appl.* 50(4) (2014) 2900–2909.
- [22] M. Mangaraj, A. K. Panda, T. Penthia, Supercapacitor supported DSTATCOM for harmonic reduction and power factor correction. In 2016 IEEE Students' Conference on Electrical, Electronics, and Computer Science (SCEECS) (2016) 1-6.
- [23] A. Stepanov, I. Galkin. Development of supercapacitor based uninterruptible power supply, Doctoral school of energy- and geo-technology (2007) Kuressaare, Estonia.
- [24] B. Espinar, D. Mayer. Photovoltaic Power Systems Program, The role of energy storage for mini-grid stabilization, International Energy Agency. IEA PVPS Task 11 (July 2011).
- [25] N. Kularatna, J. Fernando. A supercapacitor technique for efficiency improvement in linear regulators. 2009 35th Annual Conference of IEEE Industrial Electronics (2009) 132–135.
- [26] F. A. Inthamoussou, J. Pegueroles-Queralt, F. D. Bianchi. Control of a Supercapacitor Energy Storage System for Microgrid Applications. *IEEE Transactions on Energy Conversion* 28(3) (2013) 690–697.
- [27] Nippon Chemi-Con. Stanley Electric, and Tamura announce: Development of "Super CaLeCS," an environment-friendly EDLC-powered LED Street Lamp. Press Release Nippon Chemi-Con Corp., 30 March 2010.
- [28] J. R. Miller, A. F. Burke. *Electrochemical Capacitors: Challenges and Opportunities for Real-World Applications*. ECS. 17(1) (Spring 2008).
- [29] A. Jaafar, B. Sareni, X. Roboam, M. Thiounn-Guermeur. Sizing of a hybrid locomotive based on accumulators and ultracapacitors. 2010 IEEE Vehicle Power and Propulsion Conference (2010) 1–6.
- [30] M. Fröhlich, M. Klohr, St. Pagiela. Energy storage system with ultracaps on board of railway vehicles. Proceedings - 8th World Congress on Railway Research (2008), Soul, Korea, May 18-22.

- [31] H. Hondius. Supercapacitors to be tested on Paris STEEM tram. Railway Gazette. 07.08.2009, Internet: <https://www.railwaygazette.com/supercapacitors-to-be-tested-on-paris-steem-tram>
- [32] Alstom Corporation. UITP 2015: Alstom launches SRS, a new ground-based static charging system, and extends its APS solution to road transportation. Internet: www.alstom.com, 8 June 2015.
- [33] T. Hamilton, "Next Stop: Ultracapacitor Buses MIT Technology Review. Internet: Technologyreview.com. (2009-10-19). Retrieved 2013-05-29.
- [34] Anonyms. Toyota TS030 LMP1 hybrid revealed. Race car Engineering Magazine, 2012-01-24, Internet: <https://www.racecar-engineering.com/news/toyota-ts030-lmp1-hybrid-revealed/>
- [35] A. Pesaran, J. Gonder. Recent Analysis of UCAPs in Mild Hybrids, National Renewable Energy Laboratory, Golden, Colorado, 6th Advanced Automotive Battery Conference. Baltimore, Maryland. May 17–19. (2006).
- [36] P. Van den Bossche et al. The Cell versus the System: Standardization challenges for electricity storage devices EVS24. International Battery, Hybrid and Fuel Cell Electric Vehicle Symposium. Stavanger/Norway (2009).
- [37] B. K. Kim, S. Sy, A. Yu, J. Zhang. Electrochemical supercapacitor for energy storage and conversion. Handbook of Clean Energy Systems. John Wiley & Sons (2015) 1-25.
- [38] Z. Yu, L. Tetard, L. Zhai, J. Thomas. Supercapacitor electrode materials: nanostructures from 0 to 3 dimensions. Energy & Environmental Science 8(3) (2015) 702-730.
- [39] A. Burke. Ultracapacitors: Why, how, and where is the technology. Journal of Power Sources 91(1) (2000) 37-50.
- [40] G. G. Amatucci, A. DuPasquier, J. M. Tarascon. U.S. Patent No. 6,187,061. Washington DC: U.S. Patent and Trademark Office (2001).
- [41] Y. Maletin, N. Strizhakova, S. Kozachkov, A. Mironova, S. Podmogilny, V. Danilin, J. K. Aleksandrovna. U.S. Patent No. 6,697,249. Washington. DC: U.S. Patent and Trademark Office (2004).
- [42] M. E. Şahin, F. Blaabjerg, A. Sangwongwanich. Predesign Simulation of Supercapacitors Based on Simplified Equivalent Circuit Model. CYSENI 2019. Kaunas, Lithuania (2019).
- [43] Maxwell Technologies, 48V Ultra-capacitor Module, Internet: <https://eu.mouser.com/new/maxwell/Maxwell-48V-ultracapacitor/>. (accessed 20.11.2018).
- [44] S. Najib, E. Erdem. Current progress achieved in novel materials for supercapacitor electrodes: a mini-review. Nanoscale Advances. 1(8) (2019) 2817-2827.
- [45] S. Wasterlain, A. Guven, H. Gualous, J. F. Fauvarque, R. Gallay, U. T. B. M., BâtF, ... & R. Montena. Hybrid power source with batteries and supercapacitor for vehicle applications. ESCAP'06 conference (2006).
- [46] T. Kubarowitz. Charge transport and storage in a supercapacitor structure, Brno University of Technology, The Faculty of Electrical Engineering and Communication. 110 p., Ph.D. Thesis (2010).
- [47] Supercapacitor (EDLC) Basics (Part 1): What Is a Supercapacitor (EDLC)?, Murata Manufacturing Co., Ltd., (accessed 20.11.2018), Internet: <https://www.murata.com/products/emiconfun/capacitor/2015/03/24/20150324-p1>.
- [48] A. S. Krunal. Supercapacitors: Fundamentals and Applications, January 11 (2018) Internet: <https://www.electronicsforu.com/technology-trends/learn-electronics/supercapacitors-fundamentals-applications> (Accessed 27. 10 2020).
- [49] J. Gabay, Supercapacitor Options for Energy-Harvesting Systems (2013) Digi-Key Electronics Corp. Internet: <https://www.digikey.com/en/articles/supercapacitor-options-for-energy-harvesting-systems> (Accessed 27. 10 2020).
- [50] Supercapacitors from Wikipedia (2020) Internet: <https://en.wikipedia.org/wiki/Supercapacitor>, (Accessed 27. 10 2020).
- [51] X. Chen, R. Paul, L. Dai. Carbon-based supercapacitors for efficient energy storage. National Science Review 4(3) (2017) 453-489.
- [52] Z. S. Iro, C. Subramani, S. S: Dash. A Brief Review on Electrode Materials for Supercapacitor. Int. J. Electrochem. Sci. 11 (2016) 10628 – 10643.
- [53] M. V. Kiamahalleh, S. H. S. Zein, G. Najafpour, S. A. Sata, S. Buniran. Multiwalled carbon nanotubes based nanocomposites for supercapacitors: a review of electrode materials. Nano 7(02) (2012) 1230002.
- [54] M. Jayalakshmi, K. Balasubramanian. Simple capacitors to supercapacitors-an overview. Int. J. Electrochem. Sci. 3(11) (2008) 1196-1217.
- [55] S. Mohapatra, A. Acharya, G. S. Roy. The role of nanomaterial for the design of supercapacitor. Lat. Am. J. Phys. Educ. 6(3) (2012) 380.
- [56] M. Vangari, T. Pryor, L. Jiang. Supercapacitors: review of materials and fabrication methods, Journal of Energy Engineering 139(2) (2013) 72-79.
- [57] A. Burke. R&D considerations for the performance and application of electrochemical capacitors. Electrochimica Acta 53(3) (2007) 1083-1091.
- [58] J. C. E. Halper, M. S. Halper. Supercapacitors: A Brief Overview. MITRE Nanosystems Group. March (2006).
- [59] M. Y. Ho, P. S. Khiew, D. Isa, T. K. Tan, W. S. Chiu. A review of metal oxide composite electrode materials for electrochemical capacitors. Nano. 9(06) (2014)1430002.

- [60] K. Naoi, P. Simon. New materials and new configurations for advanced electrochemical capacitors. *Journal of The Electrochemical Society (JES)* 17(1) (2008) 34-37.
- [61] L. P. Yu, G. Z. Chen. Redox electrode materials for supercapatteries. *Journal Power Sources* 326 (2016) 604–612.
- [62] P. Harrop. *Supercapacitor Materials and Technology Roadmap 2019-2039*. Boston. (2018). Internet: <https://www.idtechex.com/en/research-report/supercapacitor-materials-and-technology-roadmap-2019> (Accessed 1.11.2020).
- [63] P. Harrop, R. Collins. *Supercapacitor Materials and Formats. 2020-2040*. (2020). Internet: <https://www.idtechex.com/en/research-report/supercapacitor-materials-and-formats-2020-2040/742#:~:text=Formats%20include%20structural> (Accessed 1.11.2020).
- [64] U. Fischer, R. Saliger, V. Bock, R. Petricevic, J. Fricke. Carbon aerogels as electrode material in supercapacitors. *J. Porous Mat.* 4(4) (1997) 281–285.
- [65] V. Presser, M. Heon, Y. Gogotsi. Carbide-derived carbons – From porous networks to nanotubes and graphene. *Adv. Funct. Mater.* 21(5) (2011) 810–833.
- [66] Y. Korenblit, M. Rose, E. Kockrick, L. Borchardt, A. Kvit, S. Kaskel, G. Yushin. High-rate electrochemical capacitors based on ordered mesoporous silicon carbide-derived carbon. *ACS Nano* 4 (3) (2010) 1337–1344.
- [67] Z. Weijia, L. Xiaojun, Z. Kai, J. Jin, K. I. Ozoemena, S. Chen. *Nanomaterials in advanced batteries and supercapacitors*, Cham: Springer International Publishing. Chapter 8: Carbon Materials for Supercapacitors. (2016) 271-315.
- [68] J. J. Yoo, K. Balakrishnan, J. Huang, V. Meunier, B. G. Sumpter, A. Srivastava, M. Conway, A. L. M. Reddy, J. Yu, R. Vajtai, P.M. Ajayan. Ultrathin planar graphene supercapacitors. *Nano Letters* 11 (4) (2011) 1423–1427.
- [69] T. Palaniselvam, J-B. Baek. Graphene-based 2D-materials for supercapacitors. *2D Materials*. 2(3) (2015) 032002.
- [70] M. F. El-Kady, V. Strong, S. Dubin, R. B. Kaner. Laser scribing of high-performance and flexible graphene-based electrochemical capacitors. *Science* 335(6074) (2012) 1326–1330.
- [71] R. Signorelli, D. C. Ku, J. G. Kassakian, J. E. Schindall. Electrochemical Double-Layer Capacitors Using Carbon Nanotube Electrode Structures. *Proc. IEEE*. 97(11) (2009) 1837–1847.
- [72] B. E. Conway. Transition from 'Supercapacitor' to 'Battery' Behavior in Electrochemical Energy Storage. *J. Electrochem. Soc.* 138(6) (1991) 1539–1548.
- [73] R. K. Das, B. Liu, J. R. Reynolds, A. G. Rinzler. Engineered Macroporosity in Single-Wall Carbon Nanotube Films. *Nano Letters* 9(2) (2009) 677–683.
- [74] T. Osaka, S. Komaba, X. Liu. Ionic conducting polymers for applications in batteries and capacitors. *Nonaqueous Electrochemistry* 412 (1999).
- [75] H. Gualous et al. Lithium-Ion capacitor characterization and modelling. *ESSCAP'08 –3rd European Symposium on Supercapacitors and Applications*. Rome/Italy (2008).
- [76] K. Naoi, W. Naoi, S. Aoyagi, J-I. Miyamoto, T. Kamino. New Generation "Nanohybrid Supercapacitor". *Accounts of Chemical Research* 46 (5) (2013) 1075–1083.
- [77] P. Simon, A. F. Burke. Nanostructured carbons: double-layer capacitance and more. *The electrochemical society interface*. 17(1) (2008) 38.
- [78] E. G. Yanes, S. R. Gratz, A. M. Stalcup. Tetraethylammonium tetrafluoroborate: a novel electrolyte with a unique role in the capillary electrophoretic separation of polyphenols found in grape seed extracts. *Analyst* 125(11) (2000) 1919-1923.
- [79] A. Schneuwly, R. Gallay. Properties and applications of supercapacitors. From the state-of-the-art to future trends. *PCIM Conference* (2000).
- [80] A. Laforgue, D. Yang, L. Zhang, Y. Grincourt, J. Zhang, and L. Robitaille. Development of New Generation Supercapacitors for Transportation Applications, *EV Conference VE (EMC-MEC)*, (Archived 2014-01-10).
- [81] H. C. Wu, Y. P. Lin, E. Lee et al. High-performance carbon-based supercapacitors using Al current-collector with conformal carbon coating. *Materials Chemistry and Physics* 117(1) (2009) 294–300.
- [82] R. Kotz, M. Carlen. Principles and applications of electrochemical capacitors. *Electrochimica Acta* 45(15–16) (2000) 2483–2498.
- [83] L. Du, P. Yang, X. Yu. et.al. Flexible supercapacitors based on carbon nanotube/MnO₂ nanotube hybrid porous films for wearable electronic devices *J Mater Chem. A* 2 (2014) 17561–7.
- [84] P. C. Chen, G. Shen, S. Sukcharoenchoke, et al. Flexible and transparent supercapacitor based on In₂O₃ nanowire/carbon nanotube heterogeneous films. *Appl Phys Lett*. 94(043113) (2009) 1–3.
- [85] G. K. Veerasubramani, K. Krishnamoorthy, and P. Pazhamalai et al. Enhanced electrochemical performances of graphene-based solid-state flexible cable type supercapacitor using redox-mediated polymer gel electrolyte. *Carbon*. 105(2016) 638–48.
- [86] A. B. Dalton, S. Collins, E. Munoz, et al. Super-tough carbon-nanotube fibers. *Nature* 423 (2003) 703–703.
- [87] Y. Zhang, W. Bai, X. Cheng, et al. Flexible and stretchable Lithium-Ion batteries and supercapacitors based on electrically conducting carbon nanotube fiber springs. *Angew Chem Int. Ed* 53 (2014), 14564–14568.

- [88] Z. Yang, J. Deng, X. Chen, et al. A highly stretchable, fiber-shaped supercapacitor. *Angew Chem Int. Ed* 52 (2013) 13453–13457.
- [89] T. G. Yun, B. Hwang, D. Kim D. et al. Polypyrrole-MnO₂-coated textile-based flexible-stretchable supercapacitor with high electrochemical and mechanical reliability. *ACS Appl. Mater Interfaces* 7 (2015) 9228–34.
- [90] A. Tanwilaisiri, Y. Xu, R. Zhang, D. Harrison, J. Fyson, M. Areir. Design and fabrication of modular supercapacitors using 3D printing. *Journal of Energy Storage* 16 (2018) 1-7.
- [91] İ. Yılmaz, A. Gelir, O. Yargı, U. Sahinturk, O. K. Ozdemir. Electrodeposition of zinc and reduced graphene oxide on porous nickel electrodes for high performance supercapacitors. *Journal of Physics and Chemistry of Solids* 138 (2020) 109307.
- [92] W. Gao, N. Singh, L. Song, Z. Liu, A. L. M. Reddy, L. Ci, R. Vajtai, Q. Zhang, B. Wei, and P. M. Ajayan. Direct laser writing of micro-supercapacitors on hydrated graphite oxide films. *Nature Nanotechnol* 6 (2011) 496–500.
- [93] M. F. El-Kady, V. Strong, S. Dubin, and R. B. Kaner. Laser scribing of high-performance and flexible graphene-based electrochemical capacitors. *Science* 335 (2012) 1326–1330.
- [94] K. Jost, D. Stenger, C. R. Perez, et al. Knitted and screen printed carbon-fiber supercapacitors for applications in wearable electronics. *Energy & Environmental Science* 6(9) (2013) 2698–2705.
- [95] S. Powell. Clothing the Body Electric: Fabric in Modified T-shirt can Store Electrical Charge (2012) Internet:<http://www.sc.edu/news/newsarticle.php?nid=4062#.Uo-MrMRLPNF>

Biographies



Mustafa Ergin Şahin was born in, 1978 in Trabzon, Turkey. He received his B.Sc. degree in Electrical & Electronics Engineering from Karadeniz Technical University (KTU), M.Sc. degree from Gazi University in Ankara and Ph.D. degree from KTU, Trabzon, Turkey, in 2002 and 2006, 2014, respectively. He was a Guest Researcher with TUBITAK 2219 postdoctoral research program at the Department of Energy Technology, Aalborg University from September 2018 to September 2019. He is currently an assistant professor in Electrical and Electronics Engineering Department at RTE University. He was worked at different projects on low voltage power systems and relay manufacturer for power systems. He is an active reviewer for scientific journals in the field. He is also member of the Chamber of Electrical Engineers in Turkey. His main research interests are power electronics and utilization of renewable energy. He is the author of two books in circuit analysis and measurement, electronics laboratory.



Frede Blaabjerg (S'86–M'88–SM'97–F'03) was with ABB-Scandia, Randers, Denmark, from 1987 to 1988. From 1988 to 1992, he got the PhD degree in Electrical Engineering at Aalborg University in 1995. He became an Assistant Professor in 1992, an Associate Professor in 1996, and a Full Professor of power electronics and drives in 1998. From 2017 he became a Villum Investigator. He is honoris causa at University Politehnica Timisoara (UPT), Romania and Tallinn Technical University (TTU) in Estonia.

His current research interests include power electronics and its applications such as in wind turbines, PV systems, reliability, harmonics and adjustable speed drives. He has published more than 600 journal papers in the fields of power electronics and its applications. He is the co-author of four monographs and editor of ten books in power electronics and its applications.

He has received 32 IEEE Prize Paper Awards, the IEEE PELS Distinguished Service Award in 2009, the EPE-PEMC Council Award in 2010, the IEEE William E. Newell Power Electronics Award 2014, the Villum Kann Rasmussen Research Award 2014, the Global Energy Prize in 2019 and the 2020 IEEE Edison Medal. He was the Editor-in-Chief of the IEEE TRANSACTIONS ON POWER ELECTRONICS from 2006 to 2012. He has been Distinguished Lecturer for the IEEE Power Electronics Society from 2005 to 2007 and for the IEEE Industry Applications Society from 2010 to 2011 as well as 2017 to 2018. In 2019-2020 he serves a President of IEEE Power Electronics Society. He is Vice-President of the Danish Academy of Technical Sciences too. He is nominated in 2014-2019 by Thomson Reuters to be between the most 250 cited researchers in Engineering in the world.



Ariya Sangwongwanich (S'15–M'19) received the M.Sc. and Ph.D. degree in energy engineering from Aalborg University, Denmark, in 2015 and 2018, respectively. Currently, he is working as a Postdoc Fellow at the Department of Energy Technology, Aalborg University.

He was a Visiting Researcher with RWTH Aachen, Aachen, Germany from September to December 2017. His research interests include control of grid-connected converter, photovoltaic systems, reliability in power electronics and multilevel converters. In 2019, he received the Danish Academy of Natural Sciences' Ph.D. prize and the Spar Nord Foundation Research Award for his Ph.D. thesis.